

RSL

Applications

The RSL disk filter station is composed of two or more Rotodisk filters, a filter equipped with a particular mechanical and hydraulic system that allows its automatic backwashing. Adequately assembled in series with use of hydraulic valves and a controller, they allow continuity of the irrigation cycle, reduced water waste and reduced maintenance necessary on the station. The RSL station is mainly used as primary filtration of water particularly weighted with suspended particles, or as secondary filtration downstream of the quartzite filters or sand separators.

Materials

- Filter: polyamide reinforced with fibre glass
- Collectors: HDPE
- Hydraulic valves: plastic or cast iron
- Victaulic fittings: cast iron
- Filtering element: polypropylene disks

Characteristics

- Maximum working pressure: 10 bar at 20°
- Standard filtration grade: 120 mesh
(filtration available: 80, 120, 150, 200 mesh)
- Connections: victaulic (up to 4"), flanged (over 4")
- The filtering station is supplied with air discharge valves, fittings for backwash water discharge and an automation kit
- Resists acids and fertilisers commonly used in agriculture



Load loss of single filtering element*

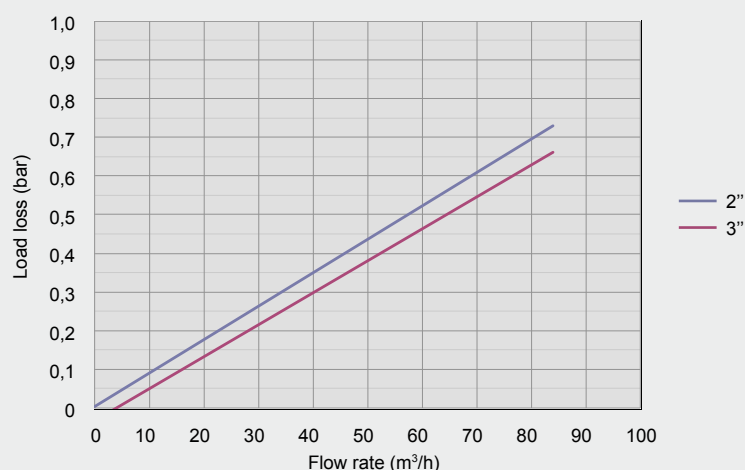

*Testing for load loss was carried out with clean water.

RSL

Technical data 2"

No. filters	Pricelist ref.	Rec. max. flow rate (m ³ /h)	Ø collector	Connections	Collector	Discharge
2	IFRSL202IVPEL	48	3" - 90mm	victaulic	HDPE	2" - 63mm
2	IFRSL202LVPEL	48	4" - 110mm	victaulic	HDPE	2" - 63mm
3	IFRSL203LVPEL	72	4" - 110mm	victaulic	HDPE	2" - 63mm
4	IFRSL204LVPEL	96	4" - 110mm	victaulic	HDPE	2" - 63mm
5	IFRSL205PFPEL	120	6" - 160mm	flanged	HDPE	2" - 63mm
6	IFRSL206PFPEL	144	6" - 160mm	flanged	HDPE	2" - 63mm

Dimensions 2"

Ø (inches - DN)	L (mm)	L1 (mm)	H (mm)	H1 (mm)	H2 (mm)
3"	630	720	1180	280	270
4"	845	720	1180	280	270
4"	845	720	1190	290	280
4"	1120	720	1190	290	280
DN150	1520	720	1220	310	300
DN150	1790	720	1220	310	300

Technical data 3"

No. filters	Pricelist ref.	Rec. max. flow rate (m ³ /h)	Ø collector	Connections	Collector	Discharge
2	IFRSL302LVPEL	64	4" - 110mm	victaulic	HDPE	3" - 90mm
3	IFRSL303LVPEL	96	6" - 160mm	flanged	HDPE	3" - 90mm
4	IFRSL304PFPEL	128	6" - 160mm	flanged	HDPE	3" - 90mm
5	IFRSL305RFPEL	160	8" - 200mm	flanged	HDPE	3" - 90mm
6	IFRSL306RFPEL	192	8" - 200mm	flanged	HDPE	3" - 90mm

Dimensions 3"

Ø (inches - DN)	L (mm)	L1 (mm)	H (mm)	H1 (mm)	H2 (mm)
4"	650	720	1180	280	230
4"	960	720	1180	280	230
DN150	1270	720	1210	310	260
DN200	1580	720	1290	380	330
DN200	1890	720	1290	380	330

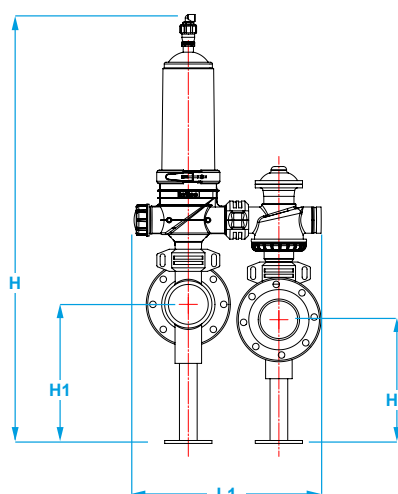
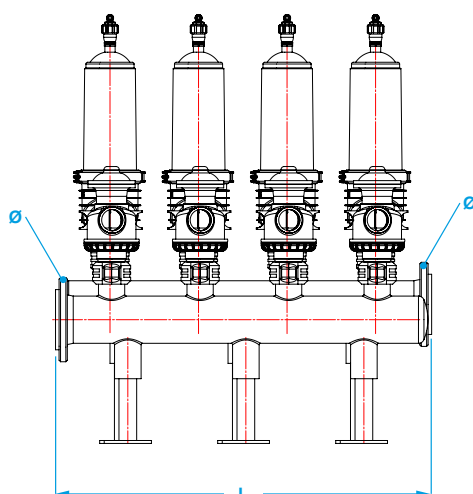

Components

Number	Description
1	air release valve
2	filter cover
3	cover o-ring
4	filtering cartridge automatic
5	stainless steel ring
6	filter body
7	cap
8	outlet collector
9	outlet collector foot
10	inlet collector foot
11	inlet collector
12	hydraulic valve 90° 3-way

